

DTR500 Solar Radiation and Precipitation Shields



The Vaisala Solar Radiation Shield Series DTR500 are available in either a 5-, 9- or 12-plate models.

The Vaisala Radiation Shield Series DTR500 are solar radiation and precipitation shields support humidity probe installations in outdoor applications.

Shield protects sensor

The maintenance-free DTR500 series shields protect the humidity and temperature sensors from solar radiation and precipitation. They provide excellent ventilation while blocking both direct and reflected solar radiation.

The special plastic used in the plates has excellent thermal characteristics; the white outer surface reflects radiation; the black inside absorbs accumulated heat. The shields can be easily installed on either a vertical pole, horizontal beam, or a flat surface.

The DTR Shields can be used with the following Vaisala probes:

- Vaisala HUMICAP® Humidity and Temperature Probe HMP155
- Vaisala HUMICAP® Humidity and Temperature Transmitter HMT337
- Vaisala HUMICAP® Humidity and Temperature Transmitter HMT100
- Vaisala INTERCAP® Humidity and Temperature transmitter HMP60
- Vaisala HUMICAP® Humidity and Temperature transmitter HMP110

Choice of models and installation accessories

Three models are available:

- Five-plate shield: Vaisala Radiation Shield DTR504 for horizontal beam installation and DTR504A including pole mast installation kit for HMT100, HMP60 and HMP110.

- Nine-plate shield: Vaisala Radiation Shield DTR502B for HMT337, PTU300 and HMP155's additional T probe
- Twelve plate shield: Vaisala Radiation Shield DTR503A for HMP155

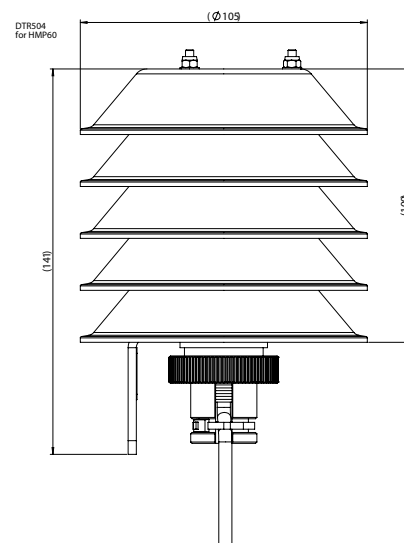

DTR504 for HMP60, HMP110 and HMT100. Refer to drawings of DTR502B for dimensions of DTR504A pole mast installation accessory.

Features/Benefits

- Protects temperature and humidity probes from scattered, as well as, direct solar radiation and rain.
- Maintenance-free
- Naturally ventilated
- Installs easily on a vertical pole, horizontal beam or flat surface
- Suitable for a wide range of applications
- Choice of shields and mounting accessories

Technical data

Dimensions

Dimensions in mm.

DTR502B
for HMT337, HMT100 and PTU300

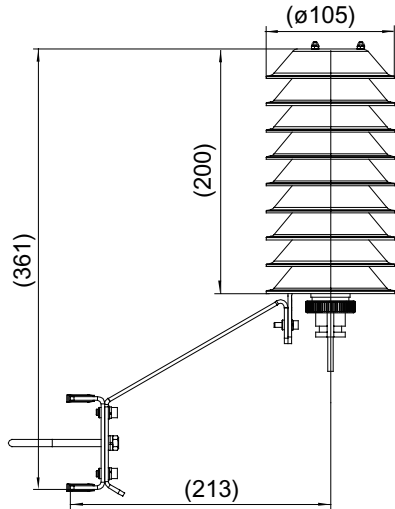

DTR502B pole mast installation.

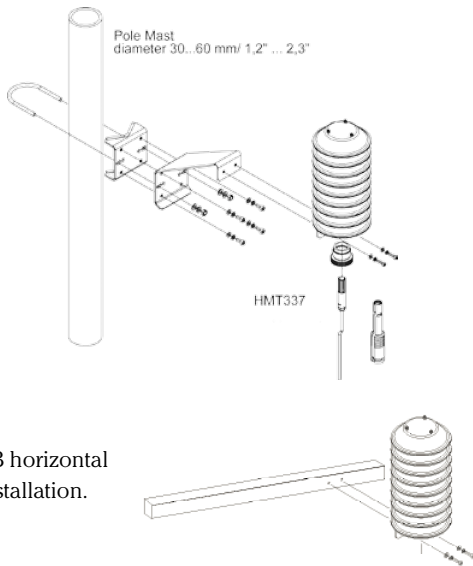

DTR502B horizontal beam installation.

Dimensions

Dimensions in mm.

DTR503A
for HMP155

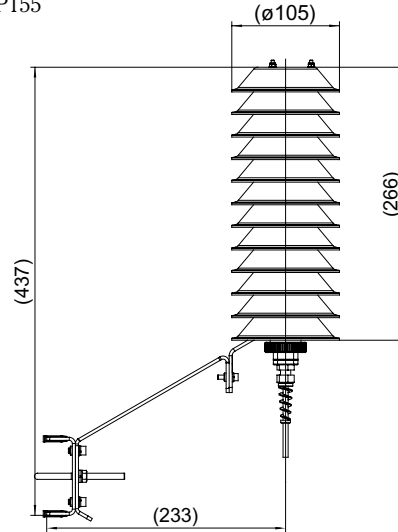

DTR503A pole mast installation.

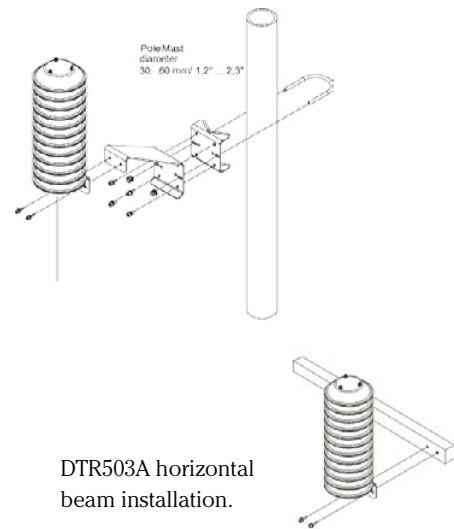

DTR503A horizontal beam installation.



For more information, visit www.vaisala.com or contact us at sales@vaisala.com

Ref. B210906EN-B ©Vaisala 2010
This material is subject to copyright protection, with all copyrights retained by Vaisala and its individual partners. All rights reserved. Any logos and/or product names are trademarks of Vaisala or its individual partners. The reproduction, transfer, distribution or storage of information contained in this brochure in any form without the prior written consent of Vaisala is strictly prohibited. All specifications — technical included — are subject to change without notice.

