

Balance Principle Self-Emptying Rain Gauge

METEOROLOGY

General Description

HyQuest Solutions' RainBal is a **rain sensor** using the balance principle combined with a continuously self-emptying collection system. This and a sophisticated firmware provides a **high resolution** as well as **precise and reliable measurements**.

The compact design allows an easy installation. Due to its **low power consumption** RainBal is ideal for remote stations powered by battery or a small solar panel. Regarding the bucket orifice different versions are available (200, 314 and 400 cm²).

RainBal meets the requirements of the WMO guidelines and delivers accurate measured values of

- one-minute intensity,
- total sum of precipitation, and
- rain duration.

Due to its compact design and its functionality, the RainBal requires only **low maintenance**. This also means less frequent site visits and less time spent per device to clean. This allows for more efficient staff planning and reduces operational costs.

In addition to our HyQuest data loggers, RainBal is compatible with other data loggers and ideal for setup and expansion of rainfall measurement networks.

RainBal achieves **very high levels of accuracy** by means of correcting the data to eliminate the influence of wind vibration, particles, unrealistic weight variations, evaporation, and temperature fluctuation.

Applications

- Agricultural Monitoring Networks
- Traffic Meteorology
- Urban and Municipalities
- Measuring Networks of Water utilities
- Flood Warning Systems

Features

- Extra low power consumption < 45 mW, no energy needed for emptying
- Evaluation and control of accuracy "in situ"
- Local and remote diagnostics
- Fully automatic continuous emptying prevents overflow and incorrect measurements
- Solid design for high MTBF
- Best-in-class design of funnel avoids blocking/clogging
- Only 0.5 s emptying time
- Output signals
 - Contact
 - Serial RS 485 / SDI12
 - USB service connector

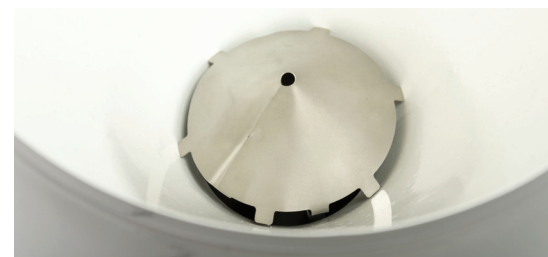

Technical Specifications

Type	PreciBal 2E15 / 3E15 / 4E15
Orifice Area	200 / 314 / 400 cm ²
Range of Precipitation	Unlimited
Accuracy absolute	±0.1 %
Accuracy relative	±1 %
Threshold Amount	0.025 mm/40 min
Threshold Intensity	0.025 mm/min
Maximum Rain Intensity	Unlimited
Resolution	0.001 mm / 0.01 mm
Measuring Element	Strain-gauge bridge
Power Supply	5 to 30 VDC / max. 4 mA@12V
Pulse Output	(1/0.1/0.01 mm) close/open
Serial Output	SDI12 / RS485 (9600 bps, 8N1)
Dimensions	ø 226 x 383 mm
Terminal Cable Length	3 m
Weight	7.0 kg
Operating Temperature Range	0 to 70 °C
Operating Humidity Range	0 to 100 %
Degree of Protection	IP65

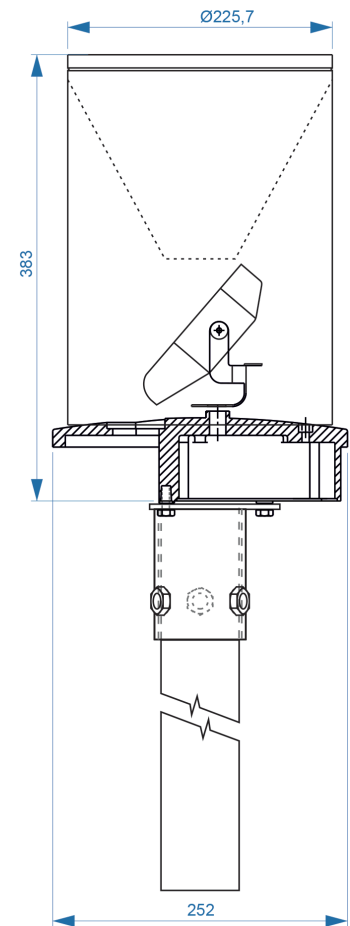

Options & Accessories

Options for PreciBal: The following features are optionally available:

- Ambient air temperature measurement (-40 to 70 °C),
- Heating (Operating temperature range -40 to 70 °C)

iRIS dataloggers and data modems:

- Robust housing
- IP over one or two channels of your choice: xG / GPRS, satellite, IoT
- I/O: analog, digital, SDI-12, Modbus
- iLink software
- Telemetry or cloud app



Bird Guard: The bird guard prevents wild or feral birds from perching or roosting and thus increases accuracy by stopping bird feces from dropping inside the gauge funnel.

Pole mount bracket: Pole mount bracket for 50 mm diameter poles. Fixed with 3x M10 bolts. Suitable for RainBal base.

Please ask for details.

Reseller

Contact Us

HyQuest Solutions Australia

- ☎ +61 2 9601 2022
- ✉ sales@hyquestsolutions.com.au
- 🌐 www.hyquestsolutions.com

HyQuest Solutions Europe

- 📍 Pascalstr. 8+10 | 52076 Aachen - Germany
- ☎ +49 2408 9385 0
- ✉ info@hyquestsolutions.eu
- 🌐 www.hyquestsolutions.eu

HyQuest Solutions New Zealand

- ☎ +64 (0)7 857 0810
- ✉ sales@hyquestsolutions.co.nz
- 🌐 www.hyquestsolutions.com

